

This manual is for reference and historical purposes, all rights reserved.

**This page is copyright© by M. Butkus, NJ.**

This page may not be sold or distributed without the expressed permission of the producer

I have no connection with any camera company

On-line camera manual library

This is the full text and images from the manual. This may take 3 full minutes for the PDF file to download.

**If you find this manual useful, how about a donation of \$3 to: M. Butkus, 29 Lake Ave., High Bridge, NJ 08829-1701 and send your e-mail address so I can thank you. Most other places would charge you \$7.50 for a electronic copy or \$18.00 for a hard to read Xerox copy.**

**This will allow me to continue to buy new manuals and pay their shipping costs.**

**It'll make you feel better, won't it?**

**If you use Pay Pal or wish to use your credit card,  
click on the secure site on my main page.**



MANUFACTURED BY:

**MAMIYA CAMERA CO., LTD.**

3-1, OTSUKA 3-CHOME, BUNKYO-KU, TOKYO, JAPAN

# mamiya/sekor 528TL



instructions



## CONTENTS

Nomenclature .....	3
Specifications.....	5
1. How to Insert the Silver Battery .....	7
2. Film Loading .....	8
3. Set Film Speed.....	9
4. Automatic Exposure Photography .....	10
5. Exposure Meter.....	11
6. Composing the Picture .....	12
7. Focusing .....	12
8. Depth of Field .....	13
9. Holding the Camera .....	13
10. Non-Automatic Operation .....	15
11. Flash Photography .....	15
12. Time Exposure Photography.....	16
13. Infra-Red Photography .....	17
14. Rewinding the Film.....	17
15. Helpful Hints .....	18

# mamiya/sekor 528 TL

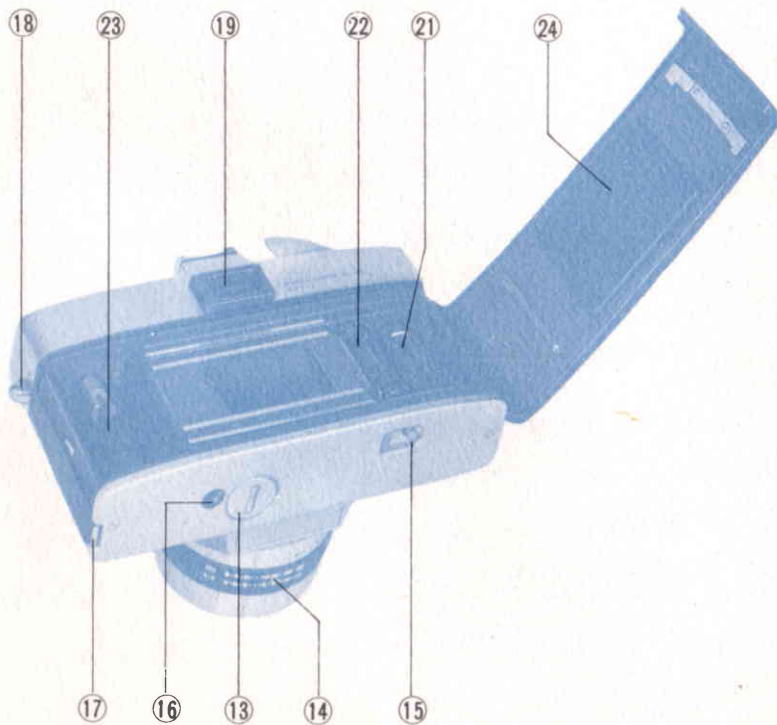

- # 15) Film Rewind Release Button
- # 16) Tripod Socket
- # 17) Back Cover Lock
- # 18) Neck Strap Eyelets
- # 19) Viewfinder
- # 20) Accessory Shoe  
(with flash contact)
- # 21) Take-Up Spool
- # 22) Film Sprockets
- # 23) Film Chamber
- # 24) Pressure Plate
- # 25) Infra-Red Mark
- # 26) Orientation Dot

# NOMENCLATURE OF

- # 1) Rapid Film Advance
- # 2) Shutter Release Button (with cable release socket)
- # 3) Automatic Reset Exposure Counter
- # 4) Focusing Ring
- # 5) Depth of Field Scale
- # 6) Shutter Speed Ring
- # 7) Aperture Adjusting Knob
- # 8) Diaphragm Ring
- # 9) B (Bulb) Setting Lever
- # 10) Flash Terminal
- # 11) Rewinding Crank
- # 12) Film Plane Indicator
- # 13) Battery Compartment Cover
- # 14) ASA Film Speed Setting Lever

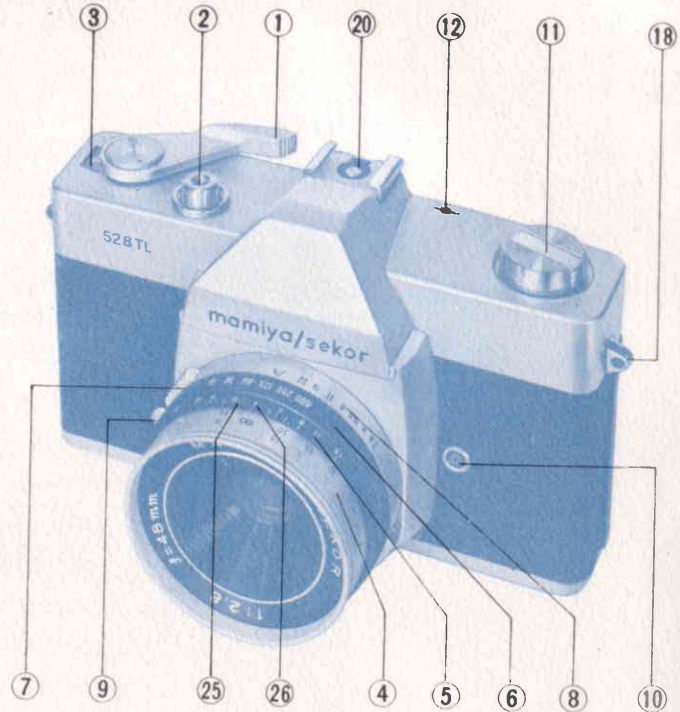

# SPECIFICATIONS OF

# mamiya/sekor 528 TL

**TYPE:** 35mm Single Lens Reflex with built-in behind the lens light meter

**FILM AND THREADING SIZE:** 35 mm (20 or 36 exposures) 24 x 36 mm

**LENS:** MAMIYA/SEKOR f/2.8—48 mm, 3 elements in 3 groups, angle 48°, filter size 52 mm

**SHUTTER:** Between the lens shutter

**SPEED:** 1/15—1/500 Second, and B (bulb)

**EXPOSURE CONTROL:** Highly sensitive CdS meter located on the back of the mirror. Accurately measures light intensity. By pre-selecting a shutter speed and turning the diaphragm ring to "A" (Automatic), the meter provides fully automatic exposure. Can also be operated manually. Operating range: EV 7 to EV 17 with an ASA 100 film.

**ASA RANGE:** 10 to 400: DIN 11 to 27

**FINDER:** Pentaprism finder with micro-diaphragm Fresnel lens for instant focusing. Aperture scale visible in the viewfinder, a needle indicates the aperture at which the photograph is being taken.

**REFLEX MIRROR:** Instant return type

**FILM ADVANCE:** 180° single stroke: advances film, cocks shutter, and advances the exposure counter

**EXPOSURE COUNTER:** Automatically returns when camera back is opened.

**DIMENSIONS:**

- Width: 5.5 inches
- Height: 3.5 inches
- Thickness: 3 inches
- Weight: 1 pound 7 ounces

## IMPORTANT

Before using the camera, put silver battery in the compartment on the bottom of the camera.

### 1 How to Insert the Silver Battery

To open battery cover (# 13), use a coin in slot on base of camera body, turning it counter-clockwise. Then insert battery, with negative (—) side down.

The battery will last approximately one year, depending upon the frequency of use. For replacement, we recommend the Eveready S 76 or equivalent. When you are not using the camera for an extended period of time, remove the silver battery.

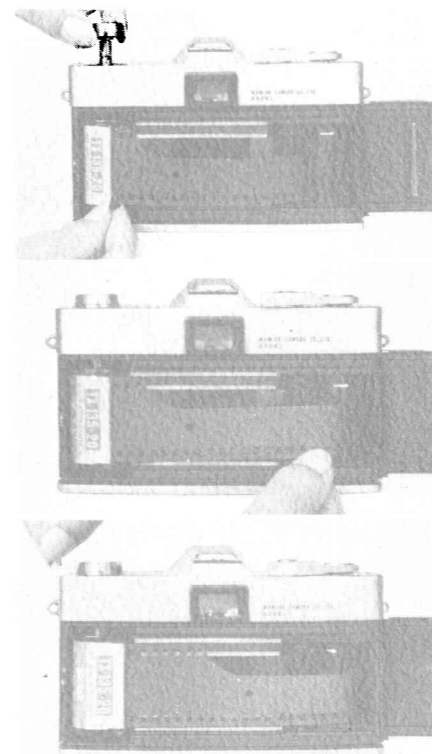
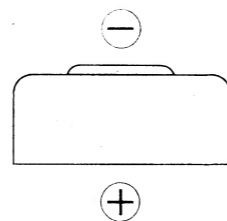
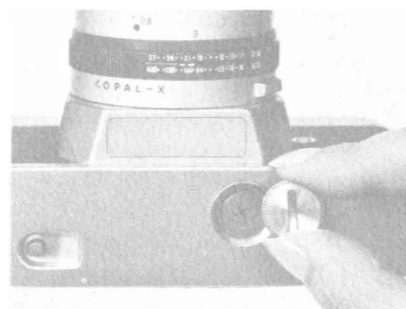

### 2 Film Loading

Do not load in bright light. Open back cover of camera by sliding back cover lock (# 17). Pull up the rewind crank knob (# 11), and put the film cartridge into the film chamber (# 23). Return the rewind crank to its former position. Draw out film leader and insert into take-up spool. If the slit is not in proper position to insert the film leader, turn the take-up spool.

Turn the rapid film advance lever, and make sure that both sprockets properly engage film perforations. Take up film slack by turning rewind crank in direction of arrow until film is taut. Close and lock back cover.

The letter "S" appears opposite the mark in the exposure counter window (# 3). Advance film a single stroke and depress shutter button after each stroke. Continue this until the figure "1" appears opposite the

## 4 Automatic Exposure Photography

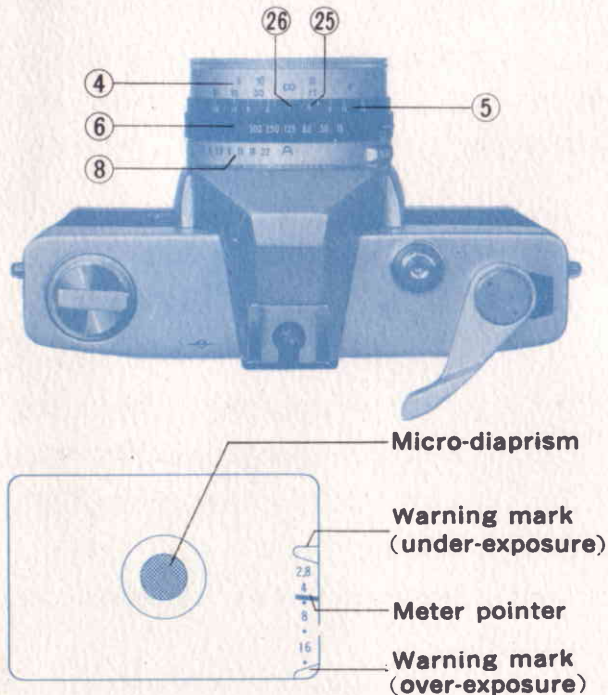

A) Turn the diaphragm ring (# 8) until A (Automatic) is aligned with the orientation dot (# 26).

B) Turn the shutter speed ring (# 6) until the desired shutter speed is aligned with the orientation dot.

A shutter speed of 1/125th of a second is recommended for most photographic requirements; however, you may need a higher shutter speed for fast moving objects or unusually bright surroundings. Where less light is available, use a slower shutter speed.

Do not attempt to turn the shutter speed ring while the shutter release button



mark. The camera is now ready for the first picture.

Each time the film is advanced, the rewind crank (#11) will turn slightly. This assures proper film action in the camera.

The shutter is automatically cocked when film is advanced: the next frame can only be advanced after the shutter is released.

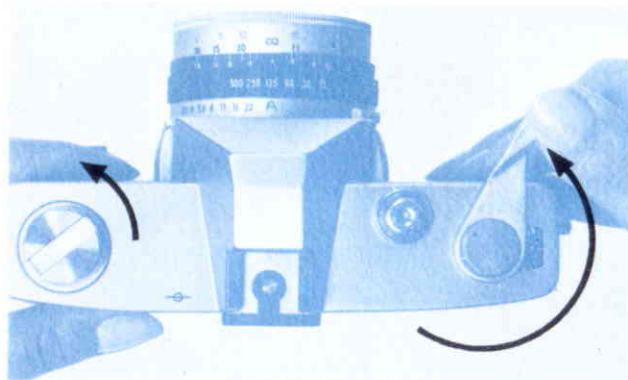

### 3 Set Film Speed

Press the ASA film speed setting lever (#14), and move it until it is lined up with the desired ASA number. The ASA scale has click stops for accurate setting.

	(12)	(20)	(32)	(40)	(50)	(80)	(125)	(160)	(250)	(320)	
ASA	10	• 16	• 25	• • •	64	• 100	• •	200	• •	400	
DIN	11	• 13	• 15	• • •	19	• 21	• •	24	• •	27	
	(12)	(14)	(16)	(17)	(18)	(20)	(22)	(23)	(25)	(26)	



is depressed.

C) The exposure meter pointer can be seen in the viewfinder on the right side. When the pointer is between the upper and lower warning marks, the picture will be properly exposed at the aperture indicated.

If the meter pointer is at the warning mark at the top of the viewfinder, move the shutter speed ring to a slower speed. When it is at the lower warning mark, move the shutter speed ring to a higher speed.

## 5 Exposure Meter

One of the most advanced features of your mamiya/sekor 528 TL camera is a built-in, behind the lens spot meter (covering about 10% of the picture area). The unique advantage of a spot meter (and the reason it is used by most professional photographers) is that you can expose for the most important subject in your picture. The meter is not affected by unimportant large, bright areas such as sky, beach or snow.

In using this system, it is not necessary to figure exposure factors, regardless of auxiliary lenses or filters used.

## 6 Composing the Picture

The mamiya/sekor 528 TL camera is a single lens reflex. You view and take the picture through the same lens. What you see in the viewfinder, you see on the film.

## 7 Focusing

Turn the focusing ring (#4) in either direction until the image in the small circle of the viewfinder becomes sharp. The mamiya/sekor micro-diaprism facilitates fast, critical focusing.

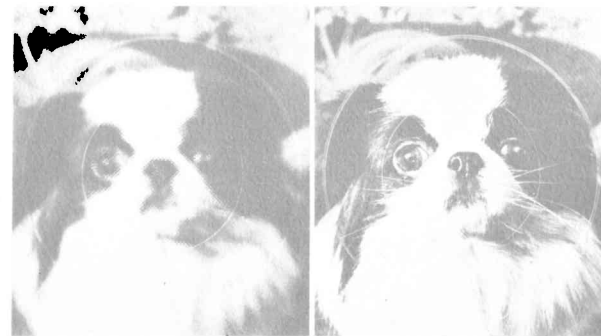

## 8 Depth of Field

A depth of field scale (#5) tells you how much of your picture will be in focus at different taking apertures. By using a smaller lens opening you can increase the area between the farthest and nearest point that will remain in focus.

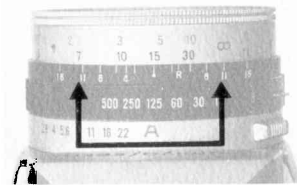

For example, with the aperture set at f/11 and focused at 15 feet, the depth of field ring (#5) indicates your subject will be in focus from 7 feet to infinity.

## 9 Holding the Camera

Holding the camera steady is very important in obtaining sharp photographs. Lightly support the bottom of the camera with the palm of the left hand; adjust the position of the camera so that the thumb and forefinger of the left hand can reach the focusing ring (#4). Place the palm of the right hand against the end of the camera body. Then the forefinger of the right hand will automatically be near the shutter release button (#2), and the thumb will be on the film advance lever (#1). Bring the viewfinder

window (#19) to the level of the eyes and rest against the forehead. This will help steady the camera.

For vertical pictures, the camera should be held with the film advance lever up. Procedure is the same as for horizontal pictures. Keep the left elbow as close to the body as possible when holding the camera.

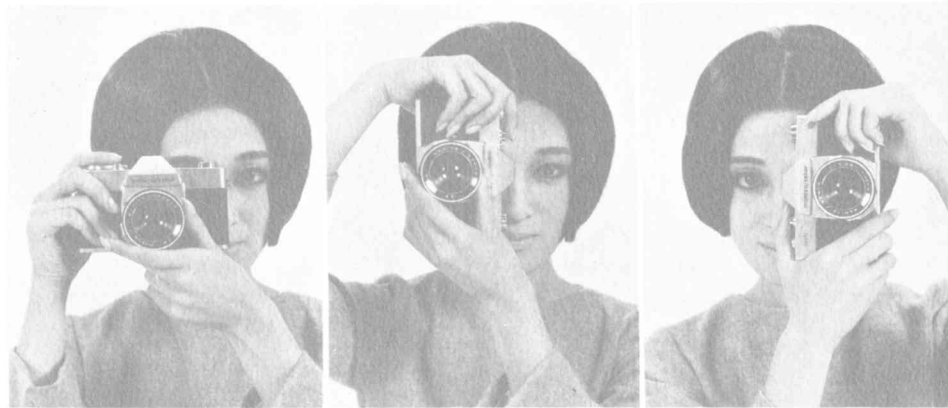

## 10 Non-Automatic Operation

When manual operation of the camera is desired, the diaphragm ring (# 8) should be turned until the desired aperture is aligned with the orientation dot. This method is used for both flash and time-exposure photography. Film advance and other operations are the same as in the case of automatic exposure photography.

The exposure pointer in the viewfinder now functions independently and is used in setting the correct aperture. However, this pointer has no relationship to time exposure photography.

## 11 Flash Photography

In flash photography, the aperture is determined by the guide number of the flash bulb, and the aperture is set manually.

Slide the flash unit into the accessory shoe, and connect the cord to the flash terminal (# 10)

1) The accessory shoe is provided with a special contact point for a cordless flash attachment.

2). The aperture is determined by dividing the guide number of the flash bulb by the distance to the subject.

$$\text{Aperture} = \frac{\text{Guide number}}{\text{Distance}}$$

The camera is equipped with X contact flash circuit. M & F class bulbs and electronic flash units may be used.

Type of Flash Bulb	Synchronization Range
M class	1/30 1/15
F class	1/60 1/30 1/15
Electronic flash	For all shutter speeds



## 12 Time Exposure Photography

Set shutter speed ring on B (bulb) by depressing bulb setting lever (# 9). The shutter will remain open as long as the shutter release button (# 2) is depressed, depending on the length of exposure desired.

## 10 Non-Automatic Operation

When manual operation of the camera is desired, the diaphragm ring (# 8) should be turned until the desired aperture is aligned with the orientation dot. This method is used for both flash and time-exposure photography. Film advance and other operations are the same as in the case of automatic exposure photography.

The exposure pointer in the viewfinder now functions independently and is used in setting the correct aperture. However, this pointer has no relationship to time exposure photography.

## 11 Flash Photography

In flash photography, the aperture is determined by the guide number of the flash bulb, and the aperture is set manually.

Slide the flash unit into the accessory shoe, and connect the cord to the flash terminal (# 10)

1) The accessory shoe is provided with a special contact point for a cordless flash attachment.

2). The aperture is determined by dividing the guide number of the flash bulb by the distance to the subject.

$$\text{Aperture} = \frac{\text{Guide number}}{\text{Distance}}$$

The camera is equipped with X contact flash circuit. M & F class bulbs and electronic flash units may be used.

Type of Flash Bulb	Synchronization Range
M class	1/30 1/15
F class	1/60 1/30 1/15
Electronic flash	For all shutter speeds



## 12 Time Exposure Photography

Set shutter speed ring on B (bulb) by depressing bulb setting lever (# 9). The shutter will remain open as long as the shutter release button (# 2) is depressed, depending on the length of exposure desired.

When making time exposures, use a tripod or rest the camera on a steady supporting base. For extremely long exposures, a cable release with locking mechanism is recommended.

## 13 Infra-Red Photography

Infra-red rays focus slightly behind the film plane normally used for ordinary light rays. This, therefore, requires a modification of normal focusing procedures. First, focus in a normal manner. Then move the focusing ring from the orientation dot to the infra-red dot (#25) on the depth of field scale ring.

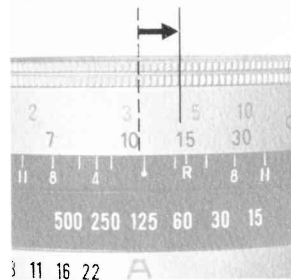

## 14 Rewinding the Film

Rewind the film into its original cartridge as follows: Push the film rewind release button (#15) of the camera. Then turn the film rewind crank (#11) in the direction of the arrow. Stop rewinding when you feel the tension on

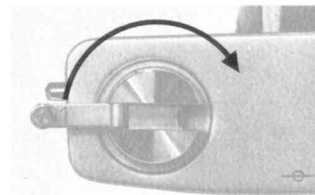
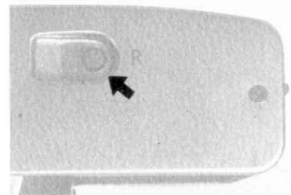

the rewind crank lessen as the leader end of the film slips off the take-up spool. Avoid direct sunlight when unloading your film.

## 15 Helpful Hints

Storage: (When the camera will not be used for a long period of time.)

- Store without cocking the shutter. This relieves spring tension.
- Remove silver battery.
- Store the camera where it will not be subject to extremes in temperature. High temperatures of over 100°F, and low temperatures of less than freezing, moisture and salty atmosphere are injurious to any camera.

When the camera does not function properly, **do not** lubricate or attempt home repairs. Contact the camera shop where the camera was purchased, or an authorized mamiya/sekor repair station.